

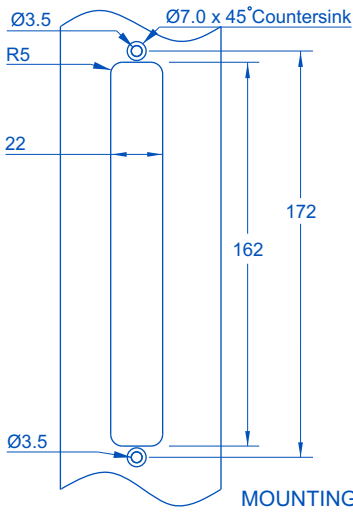

AUSTRAL
LOCK

COMMERCIAL DOUBLE FLUSHBOLT®

for aluminium doors
ILLUSTRATED FITTING INSTRUCTIONS



MOUNTING CUTOUT

Lock may be fitted to the face or edge of the door.

1.

Fit the Bolt Tubes

- Remove the face plate from lock body.
- Note:** For high use applications, apply a thread-locking compound to the threaded ends.
- Insert the threaded ends of the **bolt tubes** into the threaded holes in the **funnel slides**.
- Screw the parts together until tight.
- Ensure the arrows on the side of the **lock body** are pointing towards the top of the door, and the **funnel slides** are in the retracted position (**lever** is in the downward position).
- Slide the assembly into the door section until the **lock body** reaches the cutout.

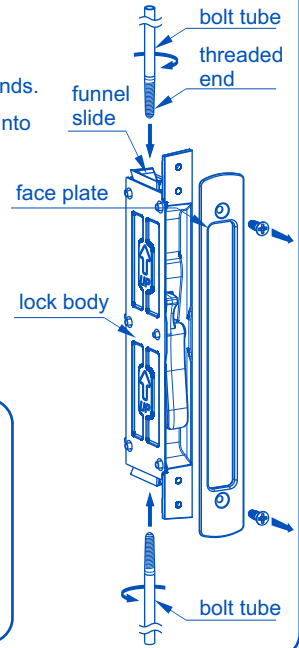

Optional

There are 3 **spacing tabs** at the back of the lock body. If required, these can be snapped off using pliers to fit the Double Flushbolt into smaller size sections.

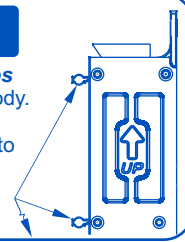

2.

Secure the Lock Body

- Secure the lock body to the door with the two G6 x 8mm CSK screws provided.
- Ensure the G6 x 8mm screw heads are flush or just below the surface of the door.
- Note:** Do not fix the face plate at this stage.

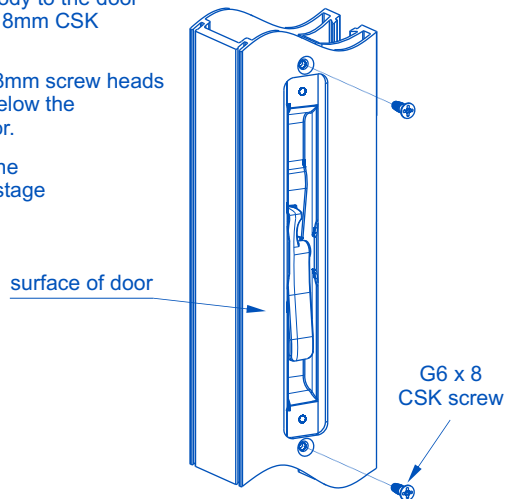

3.

Cut the Bolt Tubes

- Make sure the **bolt tubes** are in the retracted position (**lever down**) and mark the tubes level with the end of the door.
- Remove the G6 CSK screws which were used in step 2.**
- Slide the lock up to expose more of the tube. **Note:** Do not unwind the tube. Carefully mark another line 59 or 60mm below the original line and cut the **tube** ensuring a neat straight cut. Repeat this step for the bottom tube.
- Use a file to clean the cut tubes and remove burrs.

While tube is **retracted**, mark the tube level with the end of the door



Original marking

Mark and cut 59 or 60mm below original marking

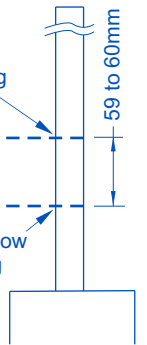

4.

Fit the Bolt Tips & Face Plate

- Insert the tip assembly into the tube at both ends of the door and crimp the tube on the flats using a pair of 'multi grip' pliers.
- Re-fix the G6 CSK screws which were used in step 2 to secure the lock body in place.**
- Fix the face plate provided to the lock body using the two G6 x 8mm CSK screws provided.

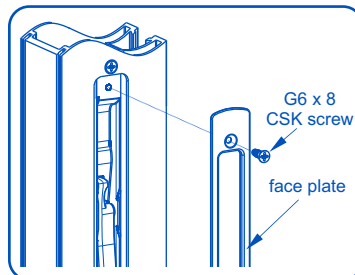
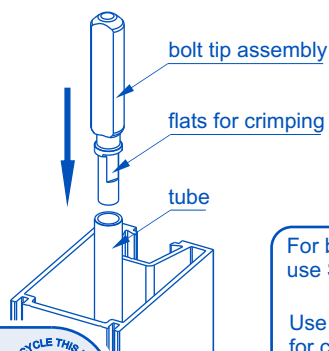

For best crimping results, use Sidchrome 28110 Multi Grip pliers

Use area indicated for crimping

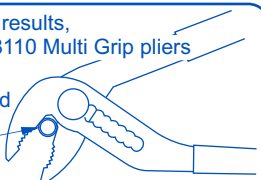

5.

Fit the 'L' Brackets

- Wind the grub screw so that it protrudes towards the 'door jamb or door stop,' also ensure that it touches the inside of the door section.
- Set the **'L' brackets** between 14 to 18mm from the top and bottom end of the door.
- Drill and countersink the front face of the door stile.
- Slide the **'L' brackets** into position over the tip. Fix the **'L' brackets** to the top and bottom of the door using the **G8 x 13mm CSK screws** as shown.

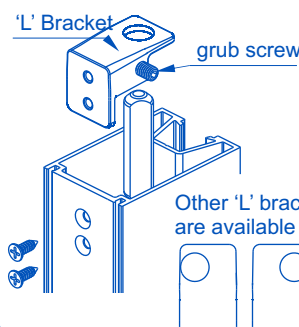

set 'L' bracket 14 to 18mm from end of door

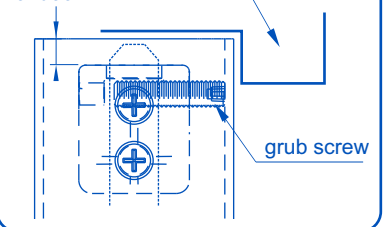

PLEASE TURN PAGE FOR INSTRUCTION STEP 6 & 7.



6.

Adjust the bolt Tips

- 1 To set the starting point of the bolt tip length, wind the tip gently with a small spanner so that when in the retracted position (lever down), the tip is level with the end of the door. This allows approximately +/- 6mm of fine adjustment.
- 2 **Note:** Ensure clearance between the bolt tip and the escutcheon or track when the bolt is fully extended to allow for door movement.

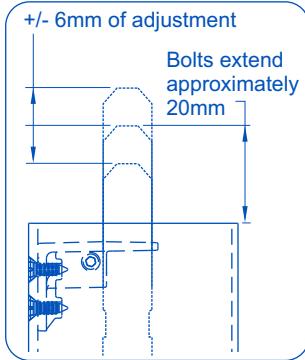
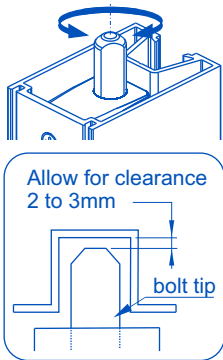

7.

Install the Escutcheons

- 1 To assemble the multipoint escutcheons, mark the center position of the remote tips on the head and sill of the door frame.
- 2 Cut out the large hole using the dimensions given.
- 3 Fix the escutcheon assembly using the #8x13mm screws provided.
- 4 To adjust the door compression, loosen the #8x13mm screws, turn the centrepiece using a screwdriver and tighten screws.
- 5 Test by closing the door & activating the Double flushbolt, repeat the steps above if further adjustment is required.

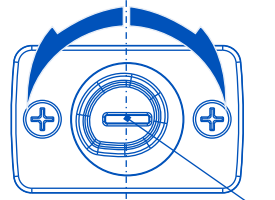

To adjust door compression, use screwdriver slot to turn centrepiece of escutcheon

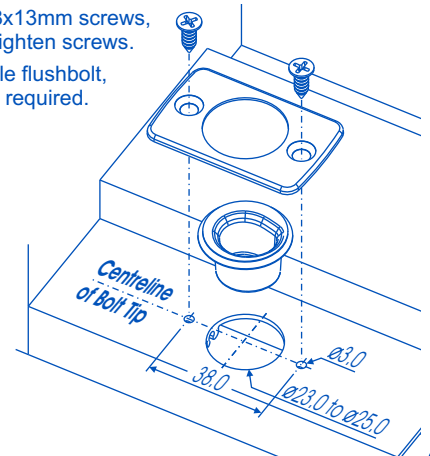

Double Flushbolt - CARE & MAINTENANCE

Installation

The product must be installed according to the instructions included in the product packaging and the door should be apertured according to the "cut-out" dimensions and tolerances shown.

Prior to fitting ensure that:

- Doors stored on site are stored in a clean dry area free from cement, lime, paint, acid etc.

During fitting of the lock ensure that :

- No metal swarf or other contaminants enter the lock body.
- The fixing screws do not damage the product finish.

After installation of the door/window ensure that:

- The door is correctly adjusted with the correct clearances.
- The lock bolts extend and retract correctly.
- The door is protected from building fall-out such as wet plaster, mortar, paint and welding splatter.

If the door becomes contaminated:

- Do not paint the fixing plate or cover plate.
- Remove wet plaster, cement, mortar and other droppings immediately, using ample clean water and a sponge or rag, to avoid permanent staining or scratching of the product finish. If removal is delayed and scraping becomes necessary the surface finish may suffer.

Maintenance

Annually inspect the door to confirm that it operates with the correct clearances, closes and opens without obstruction and confirm that the bolt tips slide freely into position - adjust the tips if necessary.

Quarterly wipe the bolt tips with a soapy rag to remove built up debris and to lubricate the tips.

NB : The Double Flushbolt assembly has been lubricated for life, and should not be disassembled by the user.

Cleaning Powder Coatings

Every six months, powder coated surfaces should be cleaned to protect the finish. However, in areas where pollutants are more prevalent, especially in coastal or industrial regions, cleaning should be carried out every two to three months.

To clean the powder coated surface:

1. Carefully remove any loose deposits with a wet sponge.
2. Use a soft brush (non abrasive) or cloth and a mild household detergent solution to remove dust, salt and other deposits. Do not use steel wool, scrapers, scouring liquids or powders to remove deposits as these permanently scratch the coating surface.
3. Rinse off with clean fresh water.

Cleaning Satin Chrome Finishes

Plated finishes are susceptible to tarnishing if they come into contact with moisture, wet paint, or water vapour. All plated finishes should be coated with a non-abrasive furniture or car wax immediately after installation. Plated finishes should be regularly wiped with a non-abrasive furniture or car wax, taking care not to scratch any protective finishes that are employed to protect the surface and prevent tarnishing.

Double Flushbolt - MAINTENANCE LOG

In order to protect your warranty, record all maintenance activity in the following log:

Address of Building :		
Name of Door:		
Date	Activity	Signed



AUSTRAL LOCK

PO Box 52
South Melbourne
Victoria 3205 Australia

ph (+61 3) 9314 1077
fax (+61 3) 9314 2400

www.ausloc.com