



# SD14

multi-point cable kit

for sliding security doors

ILLUSTRATED FITTING INSTRUCTIONS

## 1.

### Prepare Door

Prepare the door according to the table and diagram below, to suit the application.

**NOTE:** Adhere to the dimension tolerances.

	Code	[A]	[B]
High	SD14plus/H	546 mm	961 mm
Low	SD14plus/L	961 mm	546 mm
Suit 1500	SD14plus/P	375 mm	961 mm
Sample	SD14plus/S	375 mm	375 mm
		Tolerance +/- 3mm	

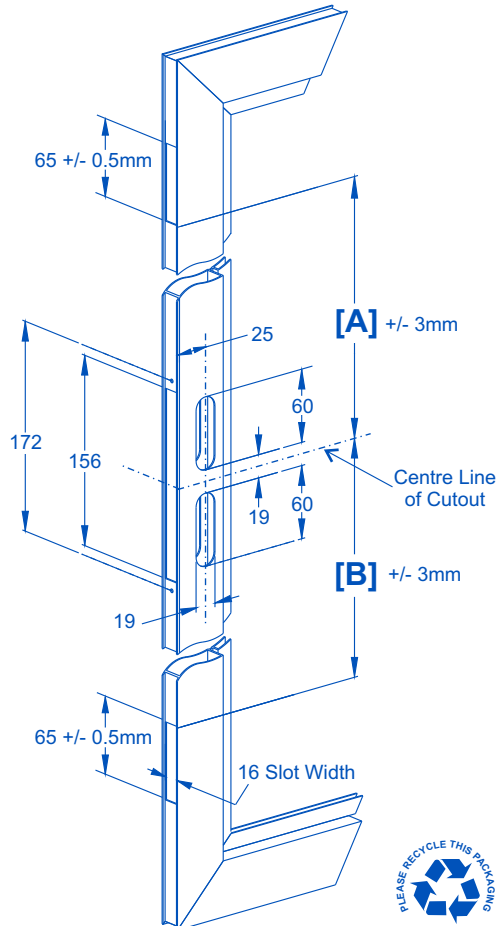

## 2.

### Assemble Connector

Ensure that a **plug** is assembled in the TOP Ø5 **drive hole** of the **drive tab** on the rear of the centrelock.

**NOTE:** The **plug** must be installed before assembling the **connector**.

Press the **connector** onto the back of the centre lock, ensuring the **connector bosses** engage in the holes at the rear of the centre lock.

Tap the **connector** with a hammer to ensure its firmly attached. Ensure that the **connector** is not bent during assembly.

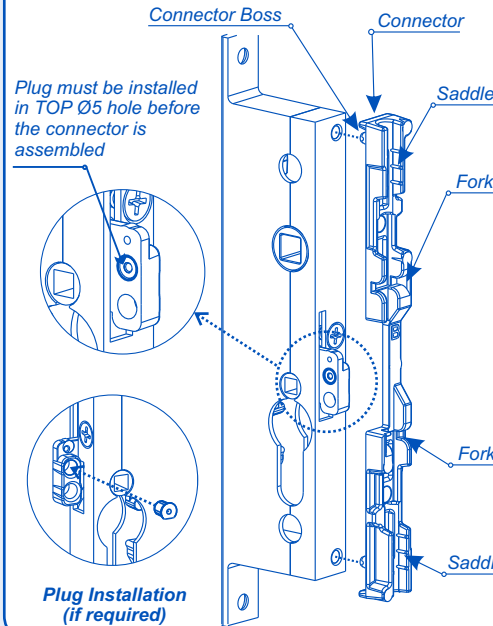

## 3.

### Identify Top & Bottom Remote Locks

To identify which remote lock is top or bottom, push the drive wire into the outer:  
If the hook bolt **UNLOCKS** it is the **BOTTOM** remote lock,  
If the hook bolt **LOCKS** it is the **TOP** remote lock.

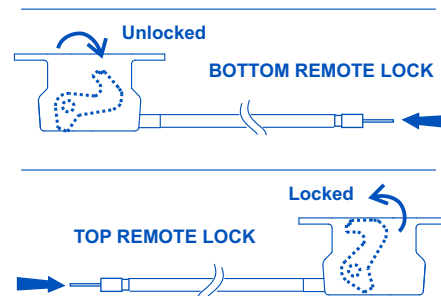

## 4.

### BOTTOM Remote Lock Installation

- Push the **slide** to the locked position. (upwards)
- Hook the **drive wire** (of BOTTOM remote lock) into the bottom Ø1.5mm **slide hole** so the tip of the wire points away from the centre case screw.
- Locate the **collar** into the **fork** on the **connector**, then push the **plastic outer** firmly into the **saddle** on the **connector**.

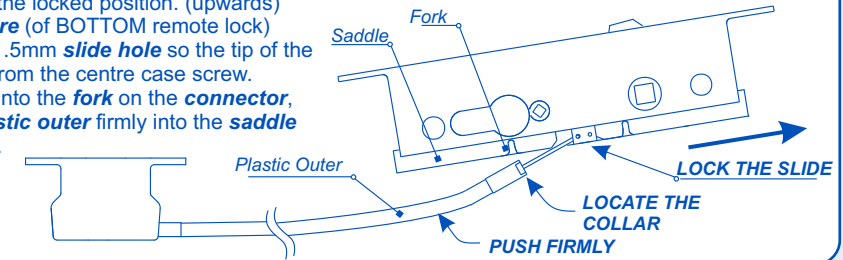

## 5.

### TOP Remote Lock Installation

- Push the **slide** to the unlocked position. (downwards)
- Slide the bottom/centre lock assembly into the section through the centre cutout.

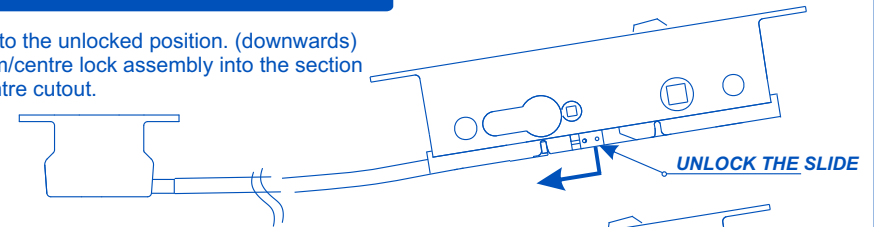

- While holding the centre lock assembly aside, slide the TOP remote lock into the section and hook the **drive wire** into the top Ø1.5mm **slide hole**.
- Lower the lock assembly into the section, ensure the **collar** locates into the **fork** on the **connector**.
- Push the **plastic outer** firmly into the **saddle** on the **connector** using a **metal strip** resting on the edges of the lever cutouts in the door section.

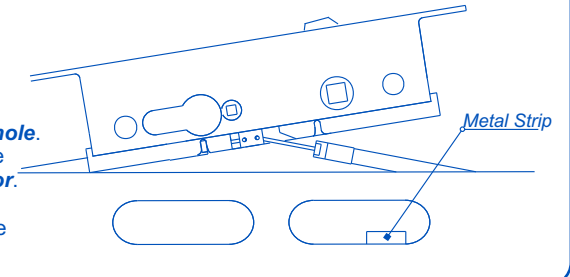

## 6.

### Secure Centrelock & Remote-Locks

#### Centrelock:

- Secure the **lockbody** to the door with two **#8x13mm lockbody screws**. (supplied with centrelock)

#### Remote-Locks:

- Place the **front plates** over the remote locks.  
**NOTE:** Ensure that the "T" marking on each **front plate** is orientated towards the TOP of the door on both top and bottom remote locks.
- Secure the **remote-locks** to the door with four **#8x25mm remote fixing screws**. (supplied with SD14)

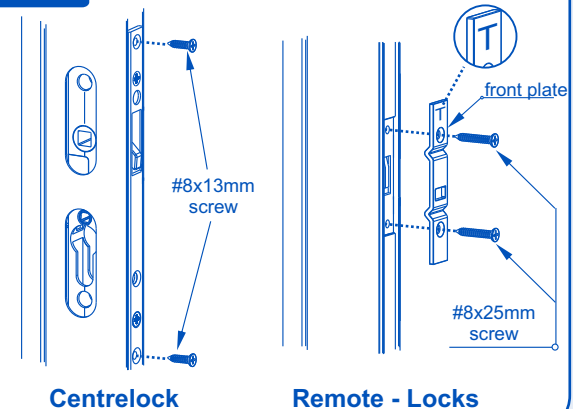

PLEASE TURN PAGE FOR STEPS 7 - 10

## 7. Cylinder Installation

The directions below must be followed carefully whenever fitting a cylinder to a centrelock with *SD14 multipoint kit* attached:

1. Insert the **snib lever**. Turn **snib lever** to vertical orientation as shown. - Lock is unlocked.
2. Position the cylinder centrally within the lock body, ensuring cam turns towards front face of door. (see diagram)
3. While applying light pressure on the **snib lever** towards the UNLOCKED position (front face of door),
4. turn the key firmly towards the locked position to engage the **cam** into the slide.
5. While turning the key, allow the **snib lever** to move while still applying light pressure.
6. Insert the #10 x 38mm **cylinder screw** and tighten

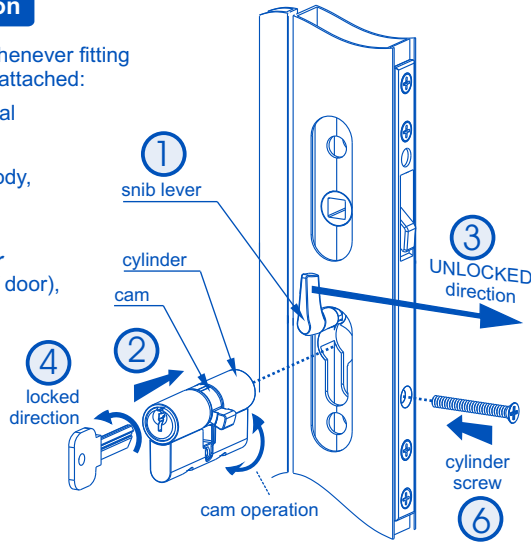

- 1 Test operation of centrelock and remote locks by locking and unlocking using the key.
- 1 Turn key back to UNLOCKED position and remove key (&snib).

## 8. Centrelock Furniture Installation

Fit the Austral Centrelock **door furniture** as per instructions supplied with the centrelock.

## 9. Centrelock Strike Plate Installation

Fit the Austral Centrelock **strike plate** as per instructions supplied with the centrelock.

## 10. Remote Strike Plate Installation

- 1 Fit the **remote strike plates** following the same process used to fit the Centre Lock Strike Plate.
- 1 Secure the **remote strike plates** to the **receiving channel** with **#8x13mm remote fixing screws** (supplied with *SD14*)

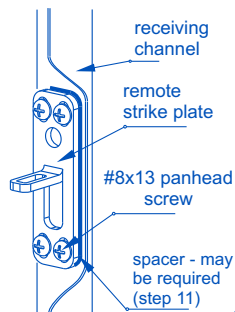

## 11. Strike Plate Spacers - If Required

As the door is being closed, check that when the **centre strike plate interlocking pin** is level with the face of the centrelock, **both remote strike plates** are level with their respective remote lock front faces (+/- 2mm).

If required, use the **strike plate spacers** supplied for adjustment.

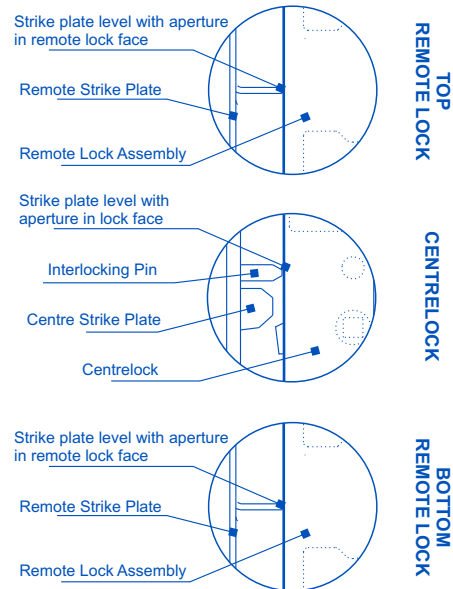

## SD14 - CARE & MAINTENANCE

### Installation

The product must be installed according to the instructions included in the product packaging and the door should be apertured according to the door "cut-out" dimensions and tolerances shown.

Prior to fitting ensure that:

Doors stored on site are stored in a clean dry area free from cement, lime, paint, acid etc.

During fitting of the lock ensure that :

No metal swarf or other contaminants enter the lock body.

The fixing screws do not damage the product finish.

After installation of the door ensure that:

The door is correctly adjusted with the correct clearances.

The lock engages the catch plate correctly.

The door is protected from building fall-out such as wet plaster, mortar, paint and welding splatter.

If the door becomes contaminated:

Do not paint the lock body or faceplate.

Remove wet plaster, cement, mortar and other droppings immediately, using ample clean water and a sponge or rag, to avoid permanent staining or scratching of the product finish. If removal is delayed and scraping becomes necessary the surface finish may suffer.

### Maintenance

Annually inspect the door to confirm that the door operates with the correct clearances, closes and opens without obstruction. Confirm that the lock tongue slides easily up the strike plate wing to freely enter the strike plate aperture when the door is closed - adjust the door if necessary.

Annually check that when the door is closed, the lock can be locked by key and by the snib lever.

NB : The lock assembly has been lubricated for life, and should not be disassembled by the user.

### Cleaning Powder Coatings

Every six months, powder coated surfaces should be cleaned to protect the finish. However, in areas where pollutants are more prevalent, especially in coastal or industrial regions, cleaning should be carried out every two to three months.

To clean the powder coated surface:

1. Carefully remove any loose deposits with a wet sponge.
2. Use a soft brush (non abrasive) or cloth and a mild household detergent solution to remove dust, salt and other deposits. Do not use steel wool, scrapers, scouring liquids or powders to remove deposits as these permanently scratch the coating surface.
3. Rinse off with clean fresh water.

### Cleaning Chrome, Satin Chrome, Gold and Brass Finishes

Plated finishes are susceptible to tarnishing if they come into contact with moisture, wet paint, or water vapour.

All plated finishes should be coated with a non-abrasive furniture or car wax immediately after installation.

Plated finishes should be regularly wiped with a non-abrasive furniture or car wax, taking care not to scratch any protective finishes that are employed to protect the surface and prevent tarnishing.

## SD14 - MAINTENANCE LOG

In order to protect your warranty, record all maintenance activity in the following log:

Address of Building :		
Name of Door :		
Date	Activity	Signed



Austral Lock

PO Box 52  
South Melbourne  
VIC 3205 Australia

ph (+61 3) 9314 1077  
fax (+61 3) 9314 2400

www.ausloc.com