

# SD7

for sliding security doors

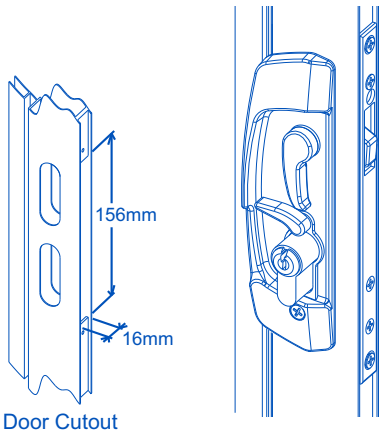

## ILLUSTRATED FITTING INSTRUCTIONS



Door Cutout

## 1. Preparation

- 1 The **sticker** on the rear of the **lockbody** is to assist in easy installation. - **Do not remove**.
- 2 If the **sticker** has been broken or removed, ensure that the **rear slide** is pushed completely down before assembling the **lockbody** into the **door cutout**.

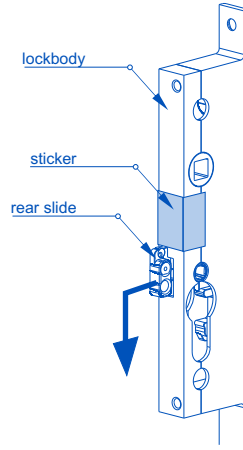

## 2. Lockbody installation

- 1 Insert the **lock body** into the **door cutout**
- 2 Secure the **lockbody** with two **#8x13mm lockbody screws**

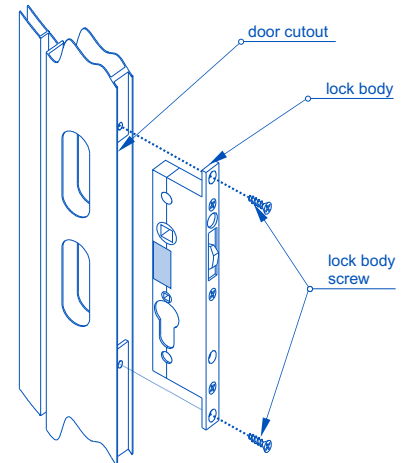

**IMPORTANT :** If installing SD7 with a multipoint accessory kit, be sure to follow the cylinder installation procedure within the multipoint kit instructions.

## 3. Cylinder Installation

- 1 Assemble the **cylinder** through the lock so the **cylinder** protrudes equally from both sides.  
**NOTE :** the cylinder **cam** must rotate as shown below. (cam turns towards front of door)
- 2 Insert the **key** and turn to locked position.
- 3 Insert **#10 x 38mm cylinder screw** & tighten.  
**NOTE :** test, **beak** should not depress.
- 4 Turn **key** to unlocked position and remove **key**.

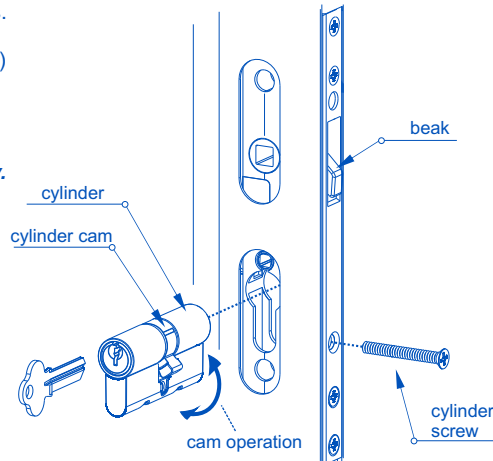

## 4. Interior Furniture Preparation

- 1 Select the interior handle assembly to suit your door, then punch out the **snib hole cover**.

**NOTE:** Punch out from the **FRONT**.

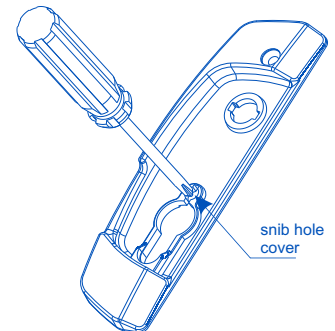

## 5. Snib Lever Selection

- 1 Break the snib lever pair in two.
- 2 **TIP :** Put the pair on a flat surface and push down on the middle.

Push down

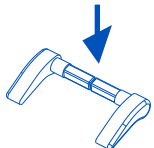

- 1 Select the correct **snib lever** according to diagram below.

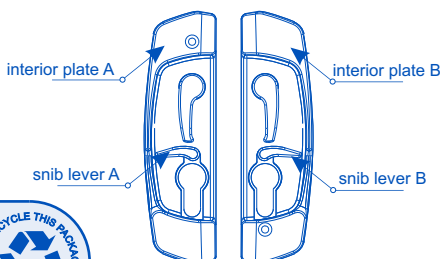

## 6. Snib Lever & Plug Assembly

- 1 Hold the **snib lever** vertical and insert it into the **snib lever hole** in the **interior handle assembly**. Turn the **snib lever** until horizontal to secure it.
- 2 Fit the **snib plug** in behind the snib hole cover of the **exterior handle assembly**.

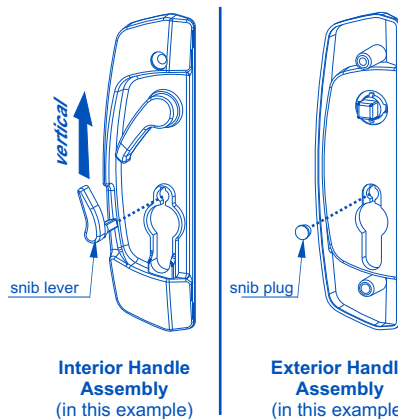

## 7. Furniture Installation

- 1 While holding the **snib lever** horizontal, place the interior and exterior handle assemblies over the lockbody.
- 2 Ensure that the **square drives** on the **lever** and **snib lever** are guided into the **lockbody**.
- 3 Secure the handle assemblies with two **#8 x 32mm handle assembly screws**.

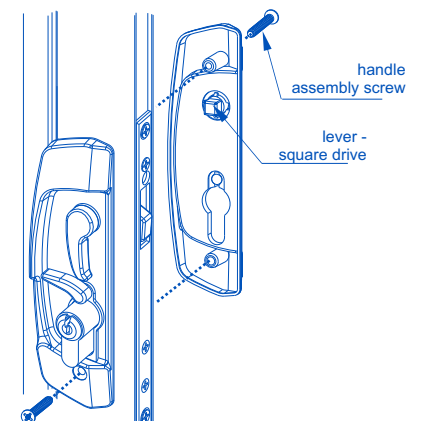

PLEASE TURN PAGE FOR INSTALLATION STEP 8.

# 8.

## Strike Plate Installation

- 1 Fit the **strike plate** into the lock.
- 2 Close the door until the **strike plate** reaches the **receiving channel**.
- 3 Mark the position of the **strike plate** on the channel.
- 4 Open the door and install the **strike plate** with two #10 x 13mm pan head screws.  
**NOTE:** Place the screws in the centre of the slots to allow for adjustment.
- 5 Test that the **strike plate** engages the lock correctly and adjust if necessary.

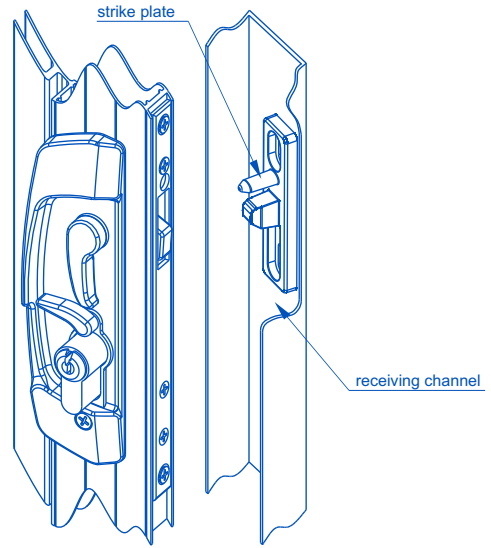

## SD7 - CARE & MAINTENANCE

### Installation

The product must be installed according to the instructions included in the product packaging and the door should be apertured according to the door "cut-out" dimensions and tolerances shown.

Prior to fitting ensure that:

Doors stored on site are stored in a clean dry area free from cement, lime, paint, acid etc.

During fitting of the lock ensure that :

No metal swarf or other contaminants enter the lock body.

The fixing screws do not damage the product finish.

After installation of the door ensure that:

The door is correctly adjusted with the correct clearances.

The lock engages the strike plate correctly.

The door is protected from building fall-out such as wet plaster, mortar, paint and welding splatter.

If the door becomes contaminated:

Do not paint the lock body or faceplate.

Remove wet plaster, cement, mortar and other droppings immediately, using ample clean water and a sponge or rag, to avoid permanent staining or scratching of the product finish. If removal is delayed and scraping becomes necessary the surface finish may suffer.

### Maintenance

Annually inspect the door to confirm that the door operates with the correct clearances, closes and opens without obstruction and confirm that the lock beak slides easily into the strike plate aperture when the door is closed - adjust the door if necessary.

Annually check that when the door is closed, the lock can be locked by key and by the snib lever.

Quarterly wipe the strike plates with a soapy rag to remove built up debris and to lubricate the strike plate.

NB : The lock assembly has been lubricated for life, and should not be disassembled by the user.

### Cleaning Powder Coatings

Every six months, powder coated surfaces should be cleaned to protect the finish. However, in areas where pollutants are more prevalent, especially in coastal or industrial regions, cleaning should be carried out every two to three months.

To clean the powder coated surface:

1. Carefully remove any loose deposits with a wet sponge.
2. Use a soft brush (non abrasive) or cloth and a mild household detergent solution to remove dust, salt and other deposits. Do not use steel wool, scrapers, scouring liquids or powders to remove deposits as these permanently scratch the coating surface.
3. Rinse off with clean fresh water.

### Cleaning Chrome, Satin Chrome, Gold and Brass Finishes

Plated finishes are susceptible to tarnishing if they come into contact with moisture, wet paint, or water vapour. All plated finishes should be coated with a non-abrasive furniture or car wax immediately after installation. Plated finishes should be regularly wiped with a non-abrasive furniture or car wax, taking care not to scratch any protective finishes that are employed to protect the surface and prevent tarnishing.

## SD7 - MAINTENANCE LOG

In order to protect your warranty, record all maintenance activity in the following log:

<b>Address of Building :</b>		
<b>Name of Door:</b>		
<b>Date</b>	<b>Activity</b>	<b>Signed</b>



**Austral Lock**

PO Box 52  
South Melbourne  
Victoria 3205 Australia

ph (+61 3) 9314 1077  
fax (+61 3) 9314 2400

[www.ausloc.com](http://www.ausloc.com)