

ELEGANCE XC

for hinged security doors

Gainsborough



ILLUSTRATED FITTING INSTRUCTIONS

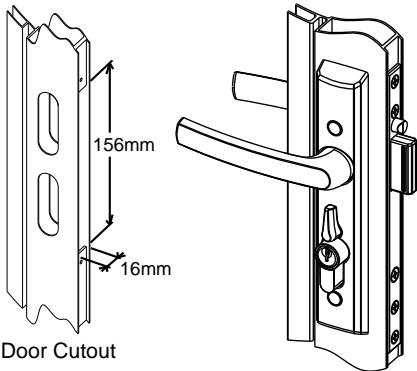

1. Preparation

- 1 The **sticker** on the rear of the **lockbody** is to assist in easy installation. - **Do not remove.**
- 2 If the **sticker** has been broken or removed, ensure that the **rear slide** is pushed completely down before assembling the **lockbody** into the **door cutout**.

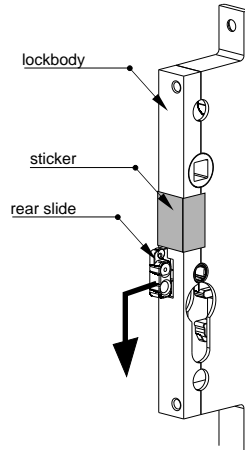

2. Fit the Lock Body

- 1 Insert the **lock body** into the **door cutout**
- 2 Secure the **lockbody** with two **#8x13mm lockbody screws**

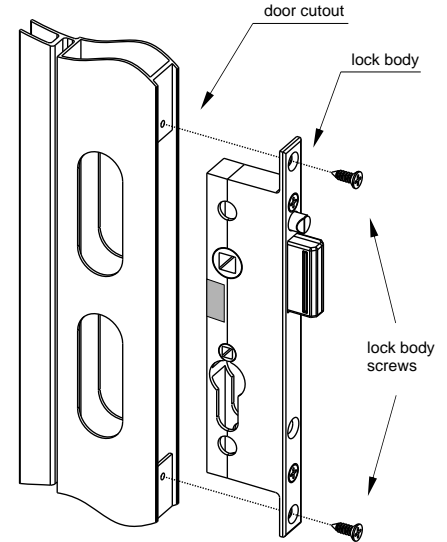

3. Install the furniture

- 1 Insert the **handle rod** through the **lock body**.
- 2 Locate the **exterior handle assembly** over the **lock body**.
- 3 Fit the two **#8x32mm screws**.
NOTE: Do not fully tighten yet.

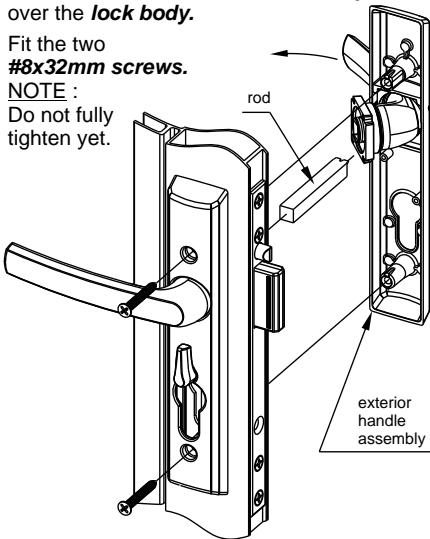

4. Cylinder installation

- 1 Assemble the cylinder through the lock so that the cylinder protrudes equally from both sides.
NOTE: the cylinder **cam** must rotate as shown below.
- 2 Press the **auxiliary bolt** to ensure the **main bolt** is fully extended.
- 3 While applying pressure on the **snib lever** towards the **unlocked** direction, turn the cylinder **key** towards the **locked** direction, until the snib lever starts to move. Continue rotating the key and allow the snib lever to rotate into the locked position.
NOTE: test, **handle** should not pull down.
- 4 Insert the **cylinder screw** and tighten.
- 5 Tighten the **handle assembly screws**.
- 6 Insert the plastic screw caps.

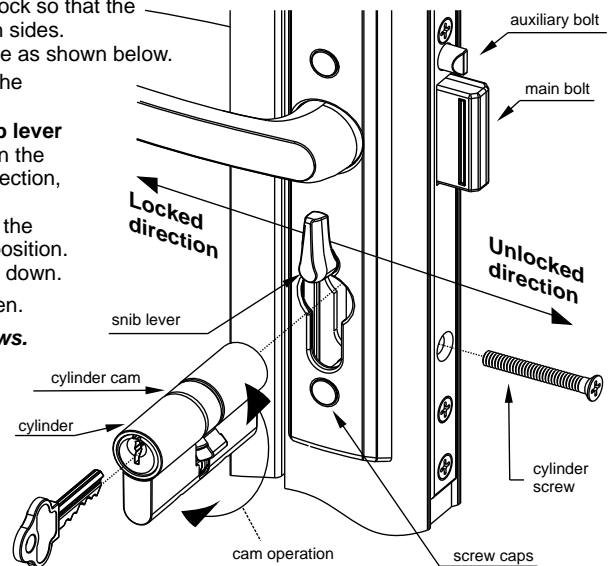

5. Position the Strike Plate

- 1 Pencil mark the **door jamb** at the same height as the **main bolt**. (refer to indicator lines below)
- 2 Center the **strike plate's square cutout** over the pencil marks on the **door jamb**.
- 3 Pencil mark the **door jamb** through the **screw holes** and the **square cutout**.
- 4 Pilot drill the **screw holes** if necessary.

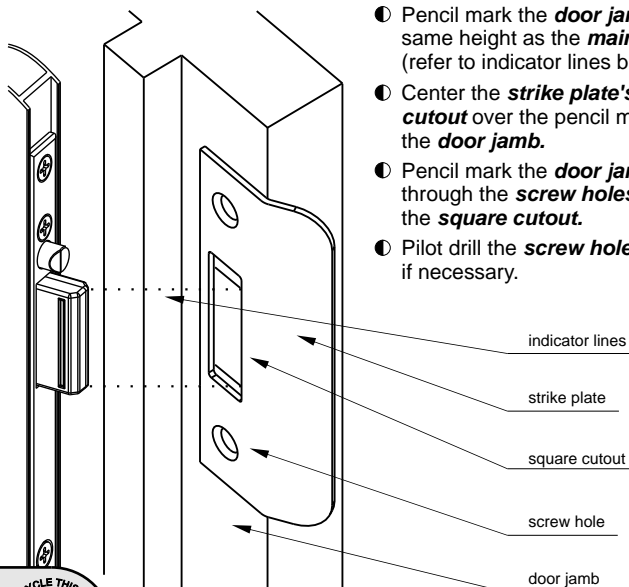

6. Install the Strike Plate

- 1 Remove the timber inside the marked square with a chisel to a **depth of 16mm** to ensure there is adequate clearance around all sides of the **main bolt**.
- 2 Secure the **strike plate** to the **door jamb** with two **#8x25mm screws**.
- 3 Test the lock. If the lock will not operate, remove more timber.

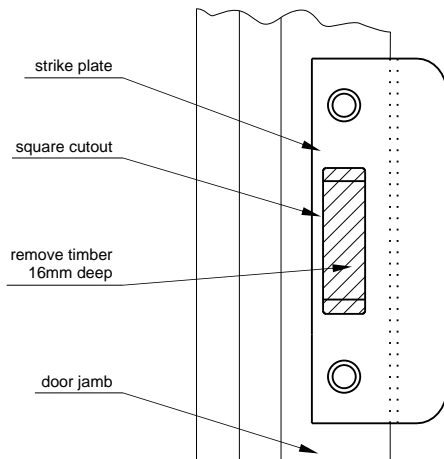

Elegance XC - CARE & MAINTENANCE

Installation

The product must be installed according to the instructions included in the product packaging and the door should be apertured according to the door "cut-out" dimensions and tolerances shown.

Prior to fitting ensure that:

- Doors stored on site are stored in a clean dry area free from cement, lime, paint, acid etc.

During fitting of the lock ensure that :

- No metal swarf or other contaminants enter the lock body.
- The fixing screws do not damage the product finish.

After installation of the door ensure that:

- The door is correctly adjusted with the correct clearances.
- The lock engages the strike plate correctly.
- The door is protected from building fall-out such as wet plaster, mortar, paint and welding splatter.

If the door becomes contaminated:

- Do not paint the lock body or faceplate.
- Remove wet plaster, cement, mortar and other droppings immediately, using ample clean water and a sponge or rag, to avoid permanent staining or scratching of the product finish. If removal is delayed and scraping becomes necessary the surface finish may suffer.

Maintenance

Annually inspect the door to confirm that the door operates with the correct clearances, closes and opens without obstruction and confirm that the lock tongue slides easily up the strike plate wing to freely enter the strike plate aperture when the door is closed - adjust the door if necessary.

Annually check that when the door is closed, the lock can be locked by key and by the snib lever.

Quarterly wipe the strike plates with a soapy rag to remove built up debris and to lubricate the strike plate (To prevent bouncing of the door).

NB : The lock assembly has been lubricated for life, and should not be disassembled by the user.

Troubleshooting

Malfunctions are usually the result of incorrect installation. Please check first that all installation steps have been followed correctly.

Firstly, always operate the lock with the door open; if it works correctly, there is a fitting problem.

Cannot insert cylinder into lock body:

- The procedure for cylinder installation has not been followed.
Unlock the cylinder with key and follow the Installation Step 5.

Cannot unlock the lock by key:

- Indicates procedure for cylinder installation has not been followed.
Unlock the cylinder using the snib, remove the cylinder. Re-install the cylinder in accordance with the installation procedure as above.

Door will not lock, or will not stay closed :

- Indicates auxiliary bolt not being tripped on closure.
Adjust the gap between door and striker plate to not more than 3mm by packing hinges or packing strike plate.
- Auxiliary Bolt is installed with bevel facing outwards so rotate the auxiliary bolt.

Lock will not lock when door is closed but will lock when door is open:

- Main bolt prevented from extending fully into strike plate hole because hole not deep enough or too narrow.
Chisel out recess to at least 16mm deep with side clearance around the bolt.

Cleaning Powder Coatings

Every six months, powder coated surfaces should be cleaned to protect the finish. However, in areas where pollutants are more prevalent, especially in coastal or industrial regions, cleaning should be carried out every two to three months.

To clean the powder coated surface:

1. Carefully remove any loose deposits with a wet sponge.
2. Use a soft brush (non abrasive) or cloth and a mild household detergent solution to remove dust, salt and other deposits. Do not use steel wool, scrapers, scouring liquids or powders to remove deposits as these permanently scratch the coating surface.
3. Rinse off with clean fresh water.



Elegance XC - MAINTENANCE LOG

In order to protect your warranty, record all maintenance activity in the following log:

Address of Building :		
Name of Door:		
Date	Activity	Signed



Austral Lock

42 Export Dr, Brooklyn
Victoria 3012 Australia
ph (+61 3) 9314 1077
fax (+61 3) 9314 2400
www.ausloc.com

A division of
GAINSBOROUGH
Hardware Industries Limited