

ULTIMATE

for hinged security doors

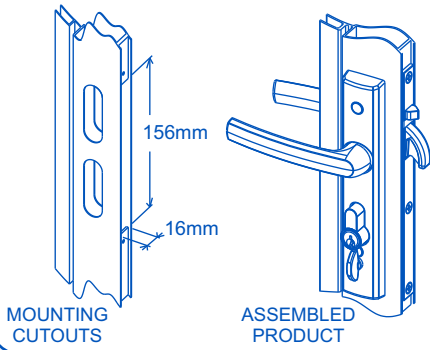

ILLUSTRATED FITTING INSTRUCTIONS



1. Fit the Lock Body

- NOTE: the lock will be supplied locked. If the beak can be pushed in, lock it by pushing the slide into the lock body.
- Insert the **lock body** into the industry standard **door cutout**.
- Secure it with the two **#8x13mm screws**.

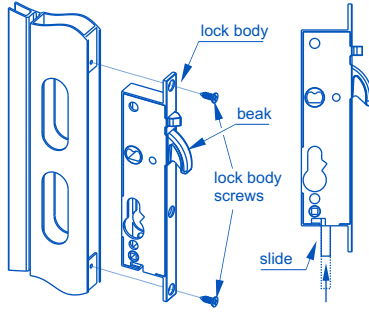

2. Cylinder installation

- Assemble the cylinder through the lock so that the cylinder protrudes equally from both sides.
NOTE: the cylinder **cam** must rotate as shown below.
- Insert the **cylinder screw**
NOTE: do not fully tighten yet.
- Insert a **key** and unlock the **lock** so the **main beak** is free to retract.

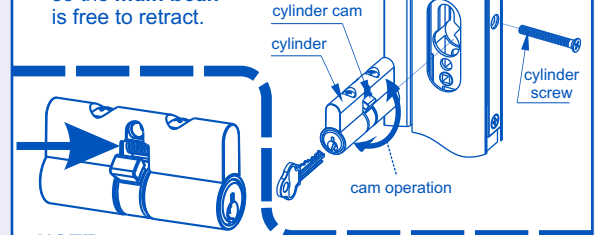

NOTE: MUST USE AUSTRAL AA8 DOUBLE PIN CYLINDER WHEN FITTING AN ULTIMATE OR HD8 LOCK.

Note: If NOT using the 'Caretaker' feature - go to Step 7.

3. 'Caretaker' feature

- If using the caretaker feature, remove screw 'A' from the caretaker cover plate, and loosen screw 'B' by one turn as shown below.
- Rotate the caretaker cover plate slightly to one side and slide the caretaker spindle behind the caretaker cover plate as shown.

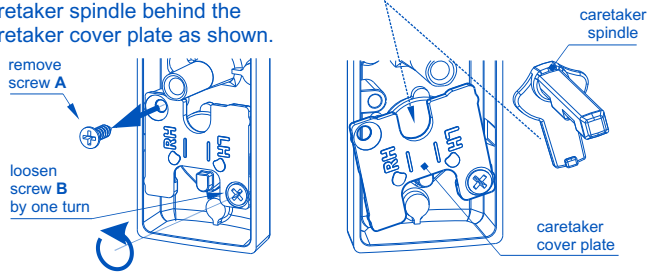

4. 'Caretaker' feature

- Secure the caretaker cover plate back in position by reinstalling screw 'A' and tightening screw 'B'.
- After screwing the caretaker cover plate in position, push the caretaker spindle upwards as far as it goes.

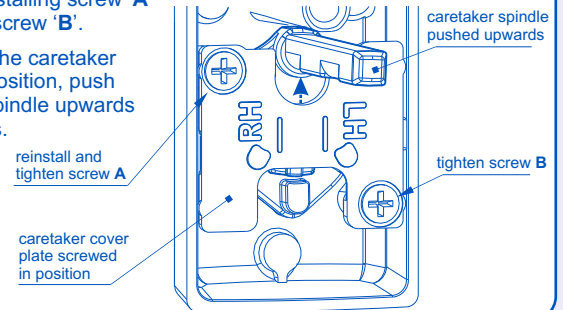

5. 'Caretaker' feature

- If using the caretaker feature, insert the caretaker key into the square hole as shown below.
- Rotate the caretaker key to position the 'D' pin on the other side for either a right hand door or a left hand door.
- When viewing the door from the outside of the house, if the hinges are on the right hand side, rotate the 'D' pin towards the right hand marks - RH. If the door hinges are on the left hand side, rotate the 'D' pin towards the left hand marks - LH as shown.

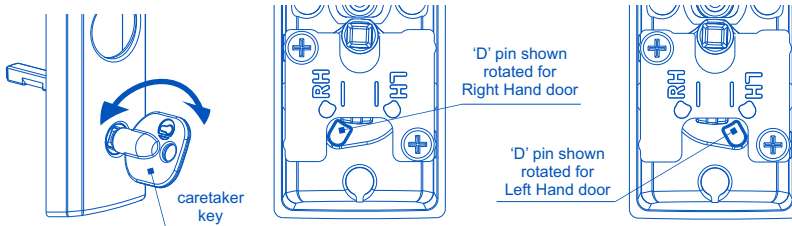

6. 'Caretaker' feature

- After positioning the 'D' pin for either a left hand door or a right hand door - as shown in step 5, push the caretaker spindle vertically down into position as shown.

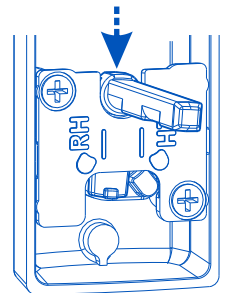

7.

- If **not** using the 'caretaker' feature, push the plastic plug which has the Austral logo, into the square hole as shown below.

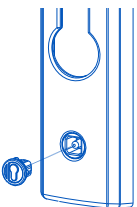

8. Fit the correct Snib Lever

- Select the **interior handle assembly** with the **snib lever hole**.
- Select the correct snib lever as shown in the box below.
- Hold the **snib lever** horizontally and insert it into the **snib lever hole**, turn it until vertical to secure it.
- If the **handle** does not point towards the door hinges, remove it from the **handle plate** and exchange with the other **handle**.
- While holding the **snib lever** vertical, place the lever assembly against the door.

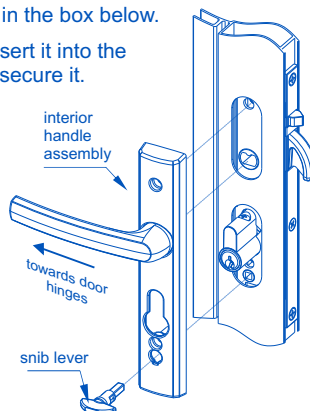

Select the correct snib lever:

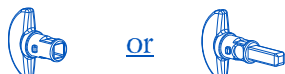

hollow snib, to use with caretaker

snib with spindle, to use without caretaker

9. Install the furniture

- Insert the **rod** through the **lock body**.
- Locate the **exterior handle assembly** over the **lock body**.
- Fit the two **#8x32mm screws**.
NOTE: do not fully tighten yet.
- Tighten the cylinder screw first, then tighten the handle screws.
- Push in plastic screw caps.

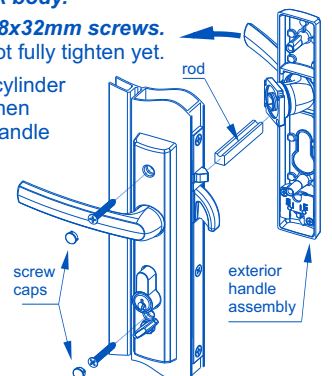

PLEASE TURN PAGE FOR INSTALLATION STEPS 10 & 11

10. Prepare the Strike Plate

- Determine the orientation of the strike plate for a Right Hand or Left Hand door, by correctly placing the strike plate on the jamb and removing the bottom tab with pliers.

Note: Bend the tab from the back of the strike plate.

remove the bottom tab with needle-nose pliers

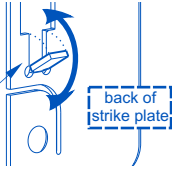

back of strike plate

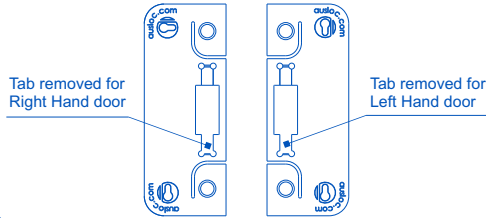

Tab removed for Right Hand door

Tab removed for Left Hand door

11. Install the Strike Plate

- Rotate a **handle** lever to withdraw the **main beak**.
- Pencil mark the **door jamb** at the same height as the **top edge of the lockcase** (refer to indicator line to the right).
- Align the **top edge of the strike plate** with the pencil mark on the **door jamb**.
- Note:** The **narrow portion of the cutout** in the strike plate must be orientated towards the ground.
- Pencil mark through the **screw holes** and **strike cutout**.
- Pilot drill the **screw holes** if necessary (Ø 2.5 on timber jamb / Ø4 on metal jamb).
- Remove the **door jamb** 15mm deep between the TOP of the **strike cutout**, and 45mm below the TOP of the strike cutout.
- Secure the **strike plate** to the **door jamb** with:
 - two **#8x25mm timber screws** on a timber jamb
 - two **#10x9mm metal screws** on a metal jamb.
- Test the fit between the **main beak** and the **strike plate** to ensure there is adequate clearance around all sides.

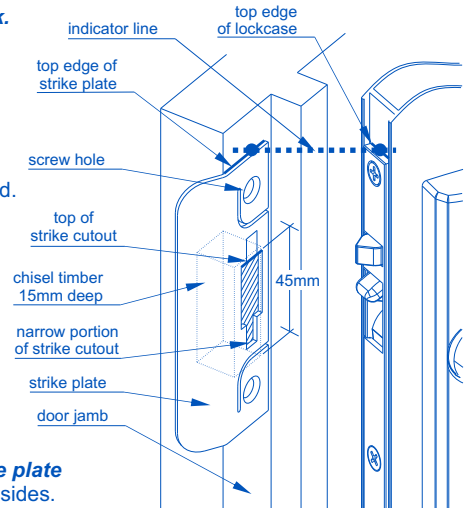

Ultimate - CARE & MAINTENANCE

Installation

The product must be installed according to the instructions included in the product packaging and the door should be apertured according to the door "cut-out" dimensions and tolerances shown.

Prior to fitting ensure that:

- Doors stored on site are stored in a clean dry area free from cement, lime, paint, acid etc.

During fitting of the lock ensure that :

- No metal swarf or other contaminants enter the lock body.
- The fixing screws do not damage the product finish.

After installation of the door ensure that:

- The door is correctly adjusted with the correct clearances.
- The lock engages the strike plate correctly.
- The door is protected from building fall-out such as wet plaster, mortar, paint and welding splatter.

If the door becomes contaminated:

- Do not paint the lock body or faceplate.
- Remove wet plaster, cement, mortar and other droppings immediately, using ample clean water and a sponge or rag, to avoid permanent staining or scratching of the product finish. If removal is delayed and scraping becomes necessary the surface finish may suffer.

Maintenance

Annually inspect the door to confirm that the door operates with the correct clearances, closes and opens without obstruction and confirm that the lock tongue slides easily up the strike plate wing to freely enter the strike plate aperture when the door is closed - adjust the door if necessary.

Annually check that when the door is closed, the lock can be locked by key and by the snib lever.

Quarterly wipe the strike plates with a soapy rag to remove built up debris and to lubricate the strike plate (To prevent bouncing of the door).

NB : The lock assembly has been lubricated for life, and should not be disassembled by the user.

Cleaning Powder Coatings

Every six months, powder coated surfaces should be cleaned to protect the finish. However, in areas where pollutants are more prevalent, especially in coastal or industrial regions, cleaning should be carried out every two to three months.

To clean the powder coated surface:

- Carefully remove any loose deposits with a wet sponge.
- Use a soft brush (non abrasive) or cloth and a mild household detergent solution to remove dust, salt and other deposits. Do not use steel wool, scrapers, scouring liquids or powders to remove deposits as these permanently scratch the coating surface.
- Rinse off with clean fresh water.

Cleaning Chrome, Satin Chrome, Gold and Brass Finishes

Plated finishes are susceptible to tarnishing if they come into contact with moisture, wet paint, or water vapour. All plated finishes should be coated with a non-abrasive furniture or car wax immediately after installation. Plated finishes should be regularly wiped with a non-abrasive furniture or car wax, taking care not to scratch any protective finishes that are employed to protect the surface and prevent tarnishing.

Ultimate - MAINTENANCE LOG

In order to protect your warranty, record all maintenance activity in the following log:

Address of Building :		
Name of Door:		
Date	Activity	Signed



Austral Lock

31 - 33 Alfred Street
Blackburn
VIC 3130 Australia

ph 13 14 18
fax 13 18 14

www.ausloc.com

A Division of
GAINSBOROUGH
Hardware Industries
Limited